

VERMEIREN

Inovys II-E

USER MANUAL



Content

Preface	2
1 Your product	3
1.1 Description	3
1.2 Accessories	4
2 Before use	5
2.1 Intended use	5
2.2 General safety instructions	5
2.3 Symbols on the wheelchair	5
2.4 Transport and (dis)assembly.....	6
2.5 First use and storage	11
3 Using your wheelchair	12
3.1 Parking brakes (only for 22"/24" wheels)	12
3.2 Drum brakes (only for 16" fixed wheels)	12
3.3 Moving to/from wheelchair	13
3.4 Comfort adjustments.....	13
3.5 Riding.....	15
3.6 Using the handset.....	18
3.7 Battery status and charging	18
4 Maintenance	21
4.1 Points of maintenance	21
4.2 Instructions of maintenance	21
4.3 Troubleshooting	22
4.4 Expected lifespan.....	22
4.5 End of use.....	22
5 Technical specifications	23

Preface

Congratulations! You are now owner of a Vermeiren wheelchair!

This wheelchair is made by qualified and committed personnel. It is designed and produced according to high quality standards guarded by Vermeiren.

Thank you for your trust in the products of Vermeiren. To support you on the use of this wheelchair and its operating options, this manual is offered. Please read it carefully; it will help you to get familiar with the operation, capabilities and limitations of your wheelchair.

If you still have questions after reading this manual, do not hesitate to contact your specialist dealer. He/she will be glad to help you.

Important note

To ensure your safety and to prolong the lifetime of your product, please take good care of it and have it checked and/serviced on a regular basis.

The warranty on this product is based on normal use and maintenance as described in this manual. Damage to your product caused by improper use or lack of maintenance will cause the warranty to lapse.

This manual reflects the latest product developments. Vermeiren has the right to implement changes to this type of product without any obligation to adapt or replace similar products previously delivered.

Pictures of the product are used to clarify the instructions in this manual. Details of the depicted product may deviate from your product.

Information available

On our website <http://www.vermeiren.com/> you will always find the most recent version of the information in this manual. Please consult this website regularly for possible updates.

Visually impaired people can download the electronic version of this manual and have it read out by means of a text-to-speech software application.



User manual
For user and specialist dealer



Installation manual
For specialist dealer



Service manual for wheelchairs
For specialist dealer

1 Your product

1.1 Description

This Inovys II-E wheelchair is easy to operate and can be used indoors as well as outdoors. It is foldable which makes it very compact to store. The wheelchair is available in multiple sizes and is easily expandable with optional parts to enhance user's comfort.

The following picture shows all parts that are relevant to the user. In the operation and maintenance section, these parts are described if applicable.

i Before using your wheelchair, check the technical details and limits of intended use, see chapter 5.



Figure 1 **Important parts**

- | | | |
|------------------------|----------------------|---------------------------------------|
| 1. Headrest (optional) | 7. Foot strap (2x) | 13. Rear wheel (2x) |
| 2. Backrest | 8. Leg rest (2x) | 14. Hand rim (2x) |
| 3. Arm pad | 9. Armrest (2x) | 15. Storage pocket with power adapter |
| 4. Handset | 10. Brake (2x) | 16. Push handle with handgrip (2x) |
| 5. Leg rest (2x) | 11. Front wheel (2x) | 17. Headrest support (optional) |
| 6. Footplate (2x) | 12. Frame | |



Figure 2 *Important parts, continued*

1.2 Accessories

Following accessories are available for the Inovys II-E:

- Wooden table (B12)
- Headrest (L55, L58)
- Personal safety belt (B58)
- Horizontal wedge (B22)
- Hemiplegic armrests (B66)

For more information, please consult your specialist dealer.

2 Before use

2.1 Intended use

In this paragraph a brief description of the intended use of your wheelchair is given. Additionally, relevant warnings are added to the instructions in the other paragraphs. In this way we would like to make you aware of the possible misuse that may appear.

- This wheelchair is suitable for indoor and outdoor use.
- This wheelchair is designed and produced solely to transport one (1) person with a maximum weight of 135kg. It is not designed for transport of goods or objects, nor for any other use than previously described.
- Depending on the type of wheels on your wheelchair, it can be operated by an attendant or by the user sitting in the wheelchair. You should NOT use this wheelchair without attendant if you suffer from physical or mental impairments that may put you, or other people, in danger when riding the wheelchair. For this reason, consult your doctor first and make sure that your specialist dealer is informed about his advice.
- This wheelchair is not intended to be used as a seat in a motorized vehicle.
- Only use accessories and spare parts approved by Vermeiren.

Please read all technical details and limits of your wheelchair in §7.

2.2 General safety instructions

 CAUTION Risk of injuries and/or damage

Please read and follow the instructions in this manual. Otherwise you may get injured or your wheelchair may get damaged.

Keep the following general warnings in mind during use:

- Do not use your wheelchair if you are under influence of alcohol, medicines or other substances that may influence your riding abilities. This also counts for your attendant operating the wheelchair.
- Be aware that some parts of your wheelchair may get very hot or cold due to ambient temperature, solar radiation or heating devices. Be careful when touching. Wear protective clothing if the weather is cold. When going outdoors, riding gloves can be used to improve the grip on the hand rims.
- Take note of the instructions for care and service. The manufacturer is not liable for damage caused by improper servicing / care.

2.3 Symbols on the wheelchair

The symbols in following list are applicable to your wheelchair. Symbols can be found in the relevant ISO standard (ISO 7000, ISO 7001 and IEC 417).



Maximum weight of the user in kg



Outdoor/indoor use (battery and power adapter excluded)



For indoor use only (battery and power adapter)



Maximum safe slope in ° (degrees).



Maximum speed



Not intended to be used as seat in a motor vehicle



Type designation

2.4 Transport and (dis)assembly

2.4.1 Moving out of the way

Move the wheelchair by using its wheels and roll it to the destination.

If this is not possible, and disassembling is not desired, ask help to lift the wheelchair. Firmly grasp the frame with both hands and lift it from the floor. Do not use foot or arm rests, or wheels to grasp the wheelchair.

2.4.2 Transport by aircraft

Since the wheelchair is equipped with a lead-acid battery, it is not possible to transport the wheelchair (as a whole) by aircraft. If you still consider to do so, consult your airline before booking your flight. It is also possible to remove the battery and buy a new one at your arrival. Contact your specialist dealer for information.

2.4.3 Transport by vehicle

 **WARNING** Risk of injuries

- Do NOT use your wheelchair as a seat in a vehicle, see symbol.
- Never use the same safety belt for passenger and wheelchair.



1. Use the handset to return your wheelchair to sitting position, see §3.6.
2. Disassemble and lift the wheelchair in the vehicle according to the instructions in §2.4.4.
3. Store the wheelchair and its parts in the luggage compartment. If luggage and passenger compartments are NOT separated or enclosed, fasten the wheelchair frame securely to the vehicle.

- i** You can use a ramp to push the wheelchair inside the vehicle, see 3.5.4.
- i** Apply the parking brakes after loading, see §3.1.

2.4.4 Assembly

 **CAUTION** Risk of injuries or damage

- Make sure that your fingers, clothes, buckles won't get trapped during assembly.
- Always keep the swing range of the footrest in mind to prevent bystanders from being injured or objects from being damaged.
- Before use, always make sure that all assembled parts have been firmly secured.



Figure 3 *Inovys II-E base frame with 16" and 24" wheels - disassembled parts*



[1]

- Place the wheelchair with four wheels on the ground.
- Fold the backrest frame (34) open.



[2]

- Mount the front of the motor to the backrest frame with the fastener pin (33) and lock its brace.
- Make sure that the backrest frame is firmly secured to the motor.



[3]

- Hang the backrest with its four screws in the four brackets (35) of the backrest frame.
- Tighten the two upper star buttons (36) by hand.
- Make sure that the backrest is firmly secured.



[4]

- Turn the star knob (37) of the armrest support anticlockwise and remove it.
- Insert the armrest (9) in the armrest support.
- Insert the star knob (37) and turn it clockwise until it is finger-tight.
- Make sure that the armrest is firmly secured.
- Repeat this for the second armrest.



[5]

- Hold the leg rest (5) sideways and hang it in the footrest support (39). Make sure that the leg rest hole (44) fits over the lower support part and that the leg rest pin (38) is inserted in the top support.
- Swing the leg rest (5) inwards until it clicks in position.
- Repeat for the second leg rest.



[6]

- Swing the footplate (6) downwards.
- Repeat for the second footplate.



[7]

- Swing the calf rest support (40) inwards.
- Turn the calf rest (8) to the back.
- Repeat this for the second calf rest.



[8]

- (If applicable) mount the headrest (1) with the square tube in the headrest support (41) on the backrest.
- Turn the star knob (42) finger tight.

Your wheelchair is now ready for use.

2.4.5 Disassembly

CAUTION Risk of injuries or damage

- Make sure that your fingers, clothes, buckles won't get entrapped during disassembly.
- Always keep the swing range of the footrest in mind to prevent bystanders from being injured or objects from being damaged.

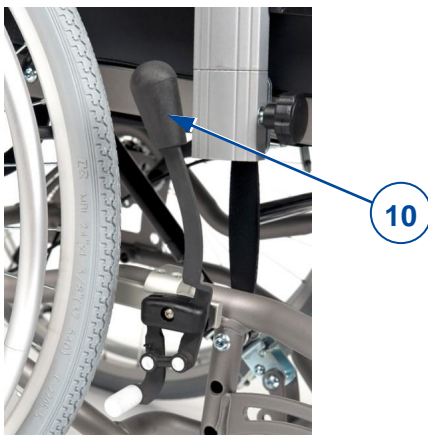

[1]

- Apply both parking brakes by operating the brake lever (10), see §3.1.

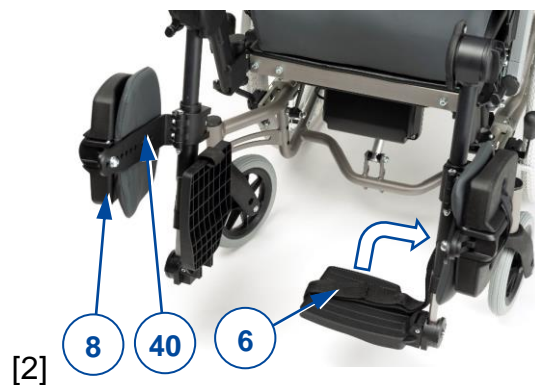

[2]

- Close the calf rest (8) and turn the calf rest support (40) outwards.
- Repeat this for the other calf rest.
- Fold both footplates (6) upwards.



[3]

- Pull the leg rest lever (50) and swing the leg rest (5) outwards.
- Lift the leg rest to remove it.
- Repeat this for the other leg rest.



[4]

- Turn the star knob (37) anticlockwise.
- Pull and hold the star knob while pulling the armrest (9) out of the armrest support.
- Retighten the star knob (37).



[5]

- (If applicable) demount the headrest (1):
 - Loosen the star knob (42) of the headrest support and remove it.
 - Pull the headrest up until it is free from the support on the backrest.



[6]

- Loosen the two upper star buttons (36) of the backrest by hand.
- Pull the backrest upwards until it is released from the four brackets (35).



[7]

- Demount the motor from the backrest frame by opening the brace of the fastener pin (33) and removing it.

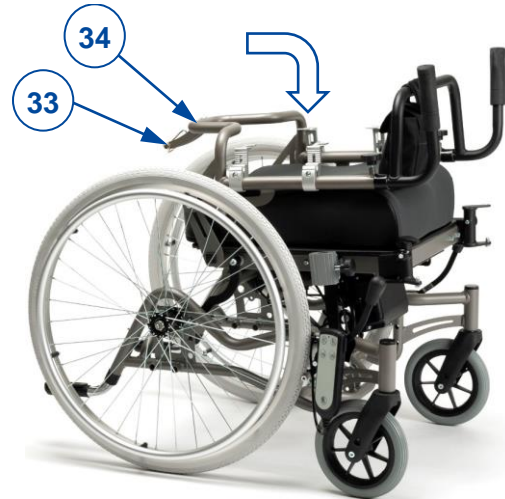

[8]

- Fold the backrest frame (34) down onto the seat.
- Place the fastener pin (33) back in the frame.

2.4.6 (Dis)Assembling rear wheels (only for 22"/24"):

For transport purposes, it might be necessary to (dis)assemble the rear wheels.

Removing the rear wheels:

1. Press and hold the button (43) while sliding the wheel axle out of the axle bushy.
2. Repeat this for the other wheel and place the wheelchair gently on the tipping caps.

Installing the rear wheels:

1. Take one of the rear wheels and lift the wheelchair on one side.
2. Press and hold the button (43) while sliding the wheel axle in the axle bushy.
3. Release the button to lock the wheel.
4. Repeat this for the other wheel. Make sure that both wheels are firmly secured.



2.5 First use and storage

CAUTION Risk of battery damage

- Never completely discharge the battery.
- Do not interrupt the charging cycle; only disconnect the battery charger when the battery is fully charged.
- Make sure that your wheelchair is stored dry to prevent mould to grow and damage the upholstery.
- Check the technical details for storage, see chapter 5.

Ensure that all battery connections are plugged in, and that the battery has been fully charged before using your wheelchair. Ask your dealer if this has already been done or not. To charge, follow the charging instructions in §3.7.

3 Using your wheelchair

WARNING

Risk of injuries

- First read the previous chapters and inform yourself about the intended use. Do NOT use your wheelchair unless you have read and fully understood all instructions.
- In case of doubts or questions, do not hesitate to contact your local specialist dealer, your care provider or technical adviser to help you.

3.1 Parking brakes (only for 22"/24" wheels)

CAUTION

Risk of injuries

- Only operate the brake lever when your wheelchair is stopped.
- An attendant should operate the brake lever if you have impaired mobility.
- Make sure the wheelchair is on a flat horizontal surface before releasing the brakes.
- Never release both brakes simultaneously.
- Brakes may only be adjusted by your specialist dealer.

CAUTION

Risk of damage

- Do not use the parking brakes to slow the wheelchair down during movement.

Your wheelchair is equipped with two manually-operated parking brakes. These brakes are intended to prevent movement of the wheelchair when parked.

Releasing brakes [A]:

1. With one hand, hold one hand rim tight (or your attendant holds the push bar with one hand).
2. Pull the brake lever (10) of the OTHER wheel to the REAR.
3. Repeat this for the second wheel and parking brake.

Applying brakes [B]:

1. With one hand, hold one hand rim tight (or your attendant holds the push bar with one hand).
2. Push the brake lever (10) of the OTHER wheel to the FRONT until you feel a distinctive lock.
3. Repeat this for the second wheel and parking brake.

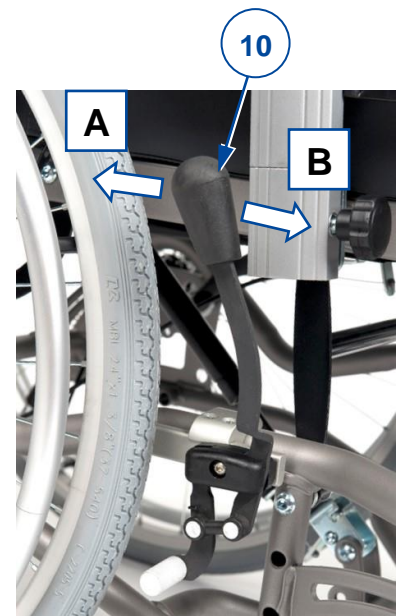

Figure 4 *Operating parking brakes*

3.2 Drum brakes (only for 16" fixed wheels)

CAUTION

Risk of injuries

- Make sure that the wheelchair is on a flat horizontal surface before releasing the brakes.
- Never release both brakes simultaneously.
- To park or stop on a slope, use the parking brakes after coming to a halt.
- Brakes may only be adjusted by your specialist dealer.

To operate the drum brakes:

1. Pull the brake levers (60) in a squeeze motion.
2. Each brake lever (60) can be blocked by pushing the lock lever (61) down with your finger.
3. Release the brake levers (60).

To move/ride again:

1. Pull the brake levers (60) in a squeeze motion. The lock lever (61) is release by this movement.
2. Hold the handgrips firmly, while releasing the brake levers (60).



Figure 5 **Operating drum brakes**

3.3 Moving to/from wheelchair

 CAUTION Risk of injuries or damage

- In case you cannot perform the transfer in a safe manner, ask someone to assist you.
- Do not stand on the footplates during transfer into or out of the chair.

Transfer

1. Position the wheelchair as close as possible to you when sitting in your chair, couch, seat or bed.
2. Apply both parking brakes to block the movement, see §3.1.
3. Use the handset to move the backrest and seat to sitting position, see §3.6.
4. Fold the footplates upwards to prevent standing on them, or turn the leg rests aside to free the passage for transfer.
5. If necessary, remove the armrest and/or leg rest on one side (see §0).
6. Transfer to/from the wheelchair using the strength of your arms, or with the help of an attendant or lifting equipment.

Sitting in the wheelchair

1. Sit down on the seat with your lower back against the backrest.
2. Reinstall the armrest and/or leg rest, if removed.
3. Turn the leg rests back to the front, fold down the footplates and put your feet on the footplates.
4. Make sure that your upper legs are horizontal and that your feet are in a comfortable position; adjust the wheelchair according to the instructions in § 3.4.

3.4 Comfort adjustments

 CAUTION Risk of injuries or damage

- The following comfort adjustments can be made by an attendant or caretaker. All other adjustments are done by your specialist dealer.
- Always keep the swing range of the footrest in mind to prevent bystanders from being injured or objects from being damaged.
- Make sure that your fingers, clothes, buckles won't get trapped during adjustment.

3.4.1 Armrest height

The arm pads (3) of the wheelchair can be adjusted in 6 different height positions:

1. Turn the star knob (45) anticlockwise to unlock.
2. Pull and hold the star knob to release the inner tube of the armrest (9).
3. Slide the inner tube of the armrest (9) up/down in the support (46) until the desired height. Make sure that the holes on the inner/outer tube align.
4. Retighten the star knob (45) by turning it clockwise.
5. Repeat this for the second armrest. Make sure that the armrests is firmly secured.



Figure 6 *Adjusting armrest height*

3.4.2 Push handles / push bar height

 CAUTION Risk of injuries

Always use the available adjustment holes on the push handle. Never exceed the maximum height adjustment.

The push handles (16) and push bar (23) are connected and can be adjusted in 7 different height positions:

1. Loosen both star knobs (31) on the handle supports and remove them.
2. Adjust the height of both push handles simultaneously by sliding them up/down in the supports. Make sure that the holes on the inner/outer tube align.
3. Insert the two star knobs (31) in the supports and the adjustment holes.
4. Turn the star knobs clockwise until they are finger-tight.
5. Make sure that the push handles are firmly secured.



Figure 7 *Adjusting push-handle height*

3.4.3 Leg rest angle

1. Loosen the lever (62) at the rotation point.
2. Adjust the angle of the leg rest by lifting/lowering the footplates (between 100° - 190°).
3. Retighten the lever (62) firmly by hand.
4. Repeat this for the second leg rest. Make sure that both leg rests are firmly secured.



Figure 8 *Adjusting footrest angle*

3.4.4 Tip cap height

1. Press and hold the spring button (63).
2. Slide the tip cap tube (64) in/out of the frame tube.
3. Release the spring button.
4. Repeat this for the second tip cap. Make sure that both tip caps are firmly secured.

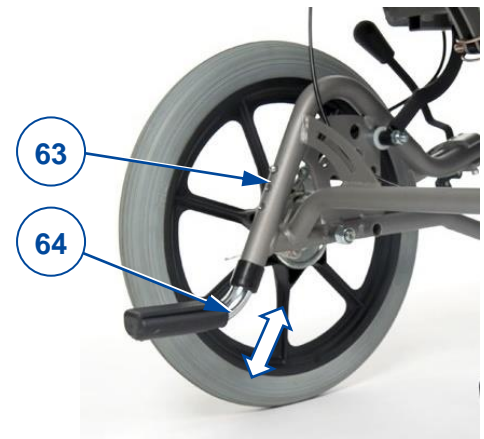

Figure 9 Adjusting tip cap height

3.5 Riding

- i** Depending on your medical condition and type of wheelchair, you can ride the wheelchair yourself or have it pushed by an attendant.

 CAUTION Risk of entrapment

- Prevent your fingers from being caught by the wheel spokes.
- Prevent getting your hands trapped on the hand rims when riding through small passages.
- When driving with an attendant, keep your arms away from the wheels and keep your feet on the footplates.

 CAUTION Risk of injuries and damage

- Do NOT drive on slopes, obstacles, steps or kerbs larger than the size described in the technical specifications in chapter 5.
- Do not proceed with your wheelchair in traffic. Always stay on the pavement.
- Do not operate the hand rims with wet hands.
- Pay attention if the road has holes or gaps that may cause entrapment of the wheels.
- Avoid stones and other objects that may block the wheels.
- Always keep the swing range of the footrest in mind to prevent bystanders from being injured or objects from being damaged.
- Before every usage, make sure that:
 - all adjustments are firmly secured, see §3.4.
 - the parking brakes are working properly.
 - the tires are in good condition, see §4.

3.5.1 Riding with an attendant

1. Release the brakes or have them released by the attendant, while he/she is holding the wheelchair to prevent movement, see §3.1 or §3.2.
2. The attendant grasps the handgrips or push bar to push the wheelchair in the desired direction.
3. After stopping, apply the brakes while holding the wheelchair in place, see §3.1 or §3.2.

3.5.2 Riding on your own

1. Release the parking brakes one by one, see §3.1.
2. Move your hands to the highest position on both hand rims.
3. Lean forward and push/turn the hand rims forward until your arms are straight.
4. Swing your arms loosely back to the topside of the hand rims and repeat the push movement.
5. To stop: wait until the wheelchair stops and move forward/backward by operating the hand rims. Apply the parking brakes one by one, see §3.1.

3.5.3 Riding on slopes

CAUTION

Risk of injuries

- If the attendant has too little strength to control the wheelchair, stop riding and use the brakes immediately.
- When you stop on a (small) slope, use your brakes, since the wheelchair may start moving unexpectedly.

1. Secure yourself in the wheelchair with a safety belt.
2. Ask an attendant or a bystander to help you.
3. Drive slowly and in a straight line. Lean slightly forward (A/B) when going up the slope. Lean backwards, against the backrest, when going down the slope.
4. Never reverse on a slope.

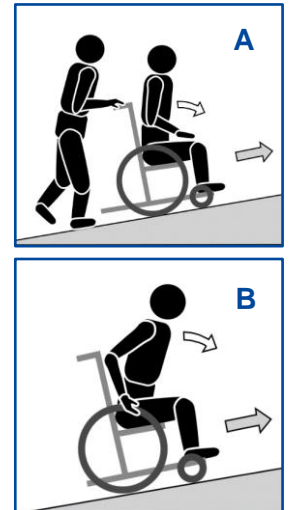
 Figure 10 *Going up a slope*

3.5.4 Using ramps

CAUTION

Risk of injuries caused by tipping over

- Only use ramps approved by Vermeiren and do not exceed their maximum load.
 - Make sure that the wheelchair does not touch the ground or ramp due to the inclination of the wheelchair.
 - Only negotiate ramps with the help of one or two attendants.
1. Adjust the position of backrest, seat and footrest to decrease the volume taken by the wheelchair and to increase the stability during inclination.
 2. Remove the footrests, see §2.4.5.
 3. Follow the instructions in §3.5.3.

3.5.5 Using stairs

CAUTION

Risk of injuries caused by tipping over

- Stairs should always be negotiated with the help of two attendants.
- Never try to use stairs that are not appropriate for wheelchairs.

To use the stairs while sitting in your wheelchair, the following instructions should be followed:

1. Remove the footrests, see §2.4.5.
2. One attendant tips the wheelchair slightly backwards by the handles.
3. The second attendant grabs the wheelchair at the front of the frame, on both sides of the wheelchair.
4. Stay calm, avoid sudden movements and keep your arms inside the wheelchair.
5. Both attendants lift and pull the wheelchair from step to step while the rear wheels roll over the steps.
6. After using the stairs, mount the footrests back in place, see §2.4.4.

 Figure 11 *Using stairs*

3.5.6 Coping with obstacles

CAUTION

Risk of injuries caused by tipping over

- Always ask assistance of one or two attendant (s).
- Make sure that the footplates won't touch ground while taking an obstacle. If necessary, remove the footrests.
- Do not use your wheelchair on an escalator.
- If available, wear your safety belt.

Small kerbs (up or down)

These can be taken forward (E / F) with one attendant:

1. The attendant moves the wheelchair forward approaching the kerb. Make sure the footplates won't touch the kerbs.
2. Lean backwards to reduce the pressure on the front wheels.
3. The attendant holds the handles firmly while moving forward. If necessary he uses the tip cap to keep the front wheels lifted until they have passed the kerb rim.
4. The attendant releases the pressure on the handles and tip cap to gently put the front wheels on the ground.
5. Next, he holds the handles firmly while pushing the wheelchair with the rear wheels up/down the kerb.

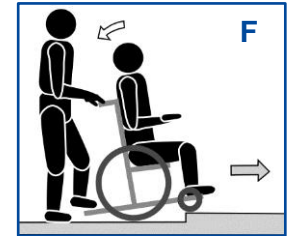

Figure 12 *Negotiating small kerbs with one attendant*

Medium kerbs (up or down)

These should be taken backwards with one attendant:

1. The attendant reverses the wheelchair so that rear wheels approach the kerb first (G / H).
2. Going down: Lean forward (G) to move your centre of gravity to the front.
3. Going up: Lean backward (H) to move your centre of gravity to the back.
3. The attendant pulls the wheelchair gently from/on the kerb.



Figure 13 *Negotiating medium kerbs with one attendant*

Higher kerbs

Higher kerbs, but below maximum size, see §5, should be taken with help of two attendants.

Going down:

1. Remove the footrests.
2. The attendant moves the wheelchair forward approaching the kerb.
3. Lean backwards to reduce the pressure on the front wheels.
4. The attendant holds the handles firmly and uses the tip cap to keep the front wheels lifted till they have passed the kerb rim.
5. The second attendant grabs the front of the frame and moves backwards while pulling the rear wheels down the kerb.
6. The first attendant releases the pressure on the handles and tip cap to put the front wheels on the ground.

Going up:

1. Remove the footrests.
2. The first attendant reverses the wheelchair so that rear wheels approach the kerb first.
3. Lean backward to move your centre of gravity to the back.
4. The second attendant grabs the front of the frame and moves forward while pulling/pushing the rear wheels on the kerb. The first attendant lifts and holds the handles firmly to prevent the wheelchair from tipping over.

3.6 Using the handset

CAUTION

Risk of injuries or damage

- Only a capable user or his/her authorized and trained staff are allowed to operate the handset.
- Be aware that the stability decreases when the wheelchair is moved from sitting upright to inclined position.

CAUTION

Risk of damage

- Make sure that there is enough space around the wheelchair to operate the backrest and seat.
- Make sure that no objects get trapped between the moving parts.

The wheelchair is delivered with a handset to operate the moveable parts. Use as follows:

1. Apply the parking brakes, see §3.1.
2. Connect the power cable to the 220/230V AC power socket.
3. Wait for at least 15 seconds. The indicator light (e) goes on.
4. To operate, press and hold one of the buttons (a – d).
5. To stop the movement, release the button.

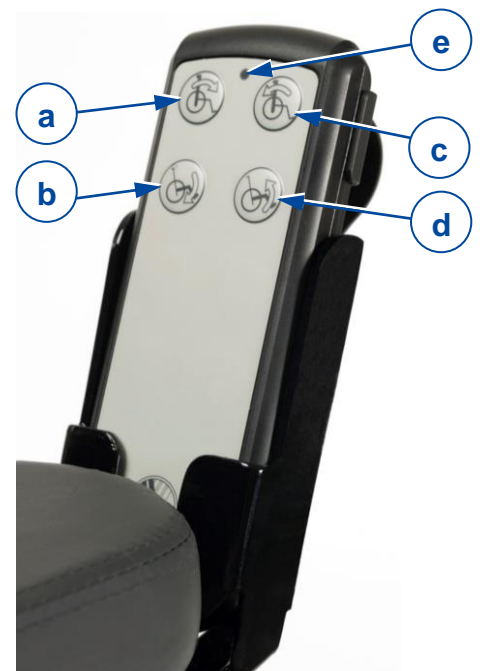

Figure 14 Handset in handset holder

Operating buttons:

- (a) Backrest – Raising to upright sitting position
- (b) Seat – Lowering to sitting position
- (c) Backrest – Lowering to reclined position
- (d) Seat – Raising to reclined position

For more information on the inclination angles of backrest and seat, see chapter 5.

3.7 Battery status and charging

WARNING

Risk of injuries and damage due to fire

- Only use the power adapter delivered with the wheelchair. The use of any other adapter may be dangerous (fire hazard).
- The power adapter is only intended to charge the battery delivered with the wheelchair, not to charge any other batteries.
- Do not adapt any of the delivered parts, like cables, plugs or power adapter. Never open or change the battery or the connection points.
- Protect the battery and power adapter against flames, high temperatures (>45°C), moisture, sunshine, severe shocks (for example dropping). Do NOT use the battery if it has been subjected to any of these circumstances.
- Charge the battery with the power adapter, indoors, in a well-ventilated area, out of children's reach. Do not use any power strip or extension cord for charging.

CAUTION

Risk of damage

- Read the storage and maintenance instructions in §4.1 and the technical details in chapter 5.
- Never completely discharge the battery.

- Do not interrupt the charging cycle; only disconnect the battery charger when the battery is fully charged.
- The lifespan reduces if the battery is exposed to extreme cold for a longer period of time.
- Keep the connection point for the power adapter free of dust and other contamination.
- Use the power adapter directly on the power-supply socket (without time switch).
- In case of any problems whereby the battery cannot be charged according to the following instructions, please contact your specialist dealer.
- Due to quiescent current, the battery will discharge itself if the wheelchair is not used for a period of time. We therefore advise you to still charge the battery regularly.

3.7.1 Battery status

The indicator light (65) on the battery housing shows the status of the battery capacity according to signalling codes in table 1.



Figure 15 Battery location on wheelchair

Table 1: Code of battery indicator

Indication code	Meaning
GREEN, continuously ON	Battery is connected to power supply and is charging normally (battery capacity between 70 and 100%). <ul style="list-style-type: none"> • Keep the battery connected to the power supply until fully charged.
GREEN, blinking fast; 1 second ON, 1 second OFF	Battery is connected to power supply and is charging normally (battery capacity below 70%). <ul style="list-style-type: none"> • Keep the battery connected to the power supply until fully charged.
GREEN, blinking slow; 0,5 second ON, 4 seconds OFF	Normal discharge of the battery (battery capacity between 25 and 100%)
ORANGE, blinking slow; 0,5 second ON, 4 seconds OFF	Battery needs charging (battery capacity below 25%). <ul style="list-style-type: none"> • Charge the battery.
ORANGE, continuously ON	Indicates a failure. The battery may be disconnected or there is an electrical problem. <ul style="list-style-type: none"> • Contact your specialist dealer for support or replacement.
Light indicator continuously OFF	Battery protection is applied and operation is blocked/stopped when: <ul style="list-style-type: none"> ◦ Overcurrent exists for more than 10 seconds ◦ Low voltage may cause over-discharging. This is when the battery capacity drops below 20%. • Charge the battery.

3.7.2 Charging the battery

To charge the battery:

1. FIRST connect the power adapter to a 230V AC power socket. The indicator (66) goes on (green) to show that the adapter is powered. If not, do not use the charger and contact your specialist dealer.
2. Plug the adapter plug (67) in the socket (68) of the charging point, see Figure 16. Make sure that the recess of the plug slides over the protruding part inside the socket.
3. Wait until the battery indicator light (66) turns green (capacity above 70%) and keep charging during the next 10 hours.
4. Disconnect the power adapter.
5. Remove the power adapter from the socket, let it cool down and store it dry in the pocket.



Figure 16 *Location of connection point*

- i** Depending on the battery condition, the battery needs to be charged for minimal 10 hours up to and more than 24 hours, when discharged below 25% capacity. Charging for a longer period won't harm the battery. The charging process can be stopped or started any time by following the instructions above.

4 Maintenance

Your wheelchair requires minimum maintenance, but it is advisable to inspect the wheelchair regularly in order to drive trouble-free for years.

4.1 Points of maintenance

 **CAUTION** Risk of injuries and damage

Repairs and replacements may only be undertaken by trained persons and only genuine replacement parts of Vermeiren should be used.

- i** The last page of this manual contains a registration form for the specialist dealer to record each service.

The service frequency depends on the frequency and intensity of use. Contact your dealer to agree to a common timetable for inspection/maintenance/repair.

Before each use

Inspect the following points:

- All parts: Present and undamaged or unworn.
- All parts: Clean, see § 4.2.2.
- Wheels, seat, leg rests, arm rests, foot rests, footplates and headrest (if applicable): Well secured.
- Battery status: Charge the battery when necessary, see §3.7.
- Handset, battery, junction box, motor, power adapter and relevant cables: No damage like wires that are frayed, broken or that become exposed.
- Condition of wheels/tyres, see § 4.2.1.
- Condition of brakes, see § 4.2.1.
- Condition of frame: No deformation, instability, weakness or loose connections
- Seat, backrest, arm pads, leg pads and head rest (if applied): No excessive wear (like dented spots, damage or tears).

Contact your specialist dealer for possible repairs or part replacements.

Every six months

If your wheelchair is stored for a longer period, you still need to charge the batteries once every 6 months for at least 24 hours. For more information, see § 3.5.

Yearly or more often

Have your wheelchair inspected and serviced by your specialist dealer, at least once a year, or more often. The minimum maintenance frequency depends on use and should therefore be commonly agreed on with your specialist dealer.

If stored

Make sure that your wheelchair is stored dry to prevent mould from growing and the upholstery from being damaged.

4.2 Instructions of maintenance

4.2.1 Wheels and tyres

- i** Proper working of the brakes depends on the state of the tyres, that can change due to wear and contamination (water, oil, mud, ...).

- Keep your wheels free of wires, hair, sand and carpet fibres.
- Check the profile of the tyres. If the tread depth is less than 1 mm, the tyres need to be replaced. Contact your specialist dealer for this matter.

4.2.2 Cleaning



CAUTION

Risk of damage by moisture

- Keep the handset clean and protect it from water and rain.
- Never use a hose or high-pressure cleaner to clean the wheelchair.

Wipe all rigid parts of the wheelchair with a damp cloth (not drenched). If necessary, use a mild soap, suitable for varnishes and synthetics.

The upholstery can be cleaned with lukewarm water and a mild soap. Do not use abrasive cleaning agents to clean.

4.2.3 Disinfection



CAUTION

Risk of damage

Disinfections may only be undertaken by trained persons. Consult your specialist dealer.

4.3 Troubleshooting

Even if you use your wheelchair properly, a technical problem may occur. In this case, contact your local specialist dealer.



WARNING

Risk of injuries and damage to the wheelchair

- NEVER attempt to repair your wheelchair yourself.

The following symptoms may indicate a serious problem. Therefore, always contact your specialist dealer if you spot any of the following deviations:

- Strange sound;
- Frayed/damaged wiring harnesses;
- Cracked or broken connectors;
- Wheelchair is powered, but operation of the handset gives no result, see §3.7.

4.4 Expected lifespan

The average lifespan of your wheelchair is 5 years. Depending on the frequency of use, driving circumstances and maintenance, the lifespan of your wheelchair will increase or decrease.

4.5 End of use

At end of life, you need to dispose your wheelchair according to the local environmental legislation. The best way to do so, is to disassemble the wheelchair to facilitate the transport of recyclable parts.

5 Technical specifications

The technical details below are only valid for this wheelchair, at standard settings and optimal ambient conditions. Take these details into account during use.

The values are no longer applicable if your wheelchair has been modified, damaged or suffers from severe wear.

Table 2: Technical specifications

Brand	Vermeiren		
Type	Wheelchair		
Model	Inovys II-E		
Description	Dimensions for all configurations		
Max. weight of user	135 kg		
Static stability downhill	10° **		
Static stability uphill	15° **		
Static stability sideways	12° **		
Obstacle climbing	60 mm		
Description	Min.	Max.	
Overall length with footrests (depends on seat-depth adjustment)	1050 mm	1090 mm	
Dismantled length without footrests (depends on seat-depth adjustment)	830 mm	870 mm	
Total height (without headrest)	990 mm	1060 mm	
Dismantled height (with folded backrest, without armrests)	710 mm	780 mm	
Seat plane angle	0°	+21°	
Effective seat depth	460 mm	520 mm	
Seat surface height at front edge (with cushion)	460 mm	530 mm	
Backrest angle	0°	+54°	
Backrest height	550 mm	585 mm	
Distance between footrest and seat	400 mm	570 mm *	
Angle foot plate	80°	100°	
Angle between seat and footrest	104°	194°	
Distance between armrest and seat	220 mm	320 mm	
Front location of armrest structure	460 mm	490 mm	
Description	Dimensions per configuration		
Diameter Rear wheels	16" (T30) with drum brakes	22"	24"
Hand rim diameter	NA	NA	535 mm
Effective seat width	400 mm	450 mm	500 mm
Overall width (depends on the seat width)	630 mm	680 mm	730 mm
Dismantled width (without armrest)	600 mm	650 mm	700 mm
Footplate width (minimum – maximum)	44-46 mm	48-50 mm	48-50 mm
Diameter steering wheels	200 mm	200 mm	200 mm
Horizontal location of axle (deflection)	-8 mm - 41 mm	-4 mm - 42 mm	-4 mm - 42 mm
Total mass	44,3 kg	43,7 kg	43,9 kg

Mass of heaviest part	32,5 kg	27,95 kg	27,95 kg
Masses of removable parts			
Footrests	4,90 kg	4,90 kg	4,90 kg
Armrests	3,45 kg	3,45 kg	3,45 kg
Rear wheels	NA	3,90 kg	4,15 kg
Backrest	3,45 kg	3,45 kg	3,45 kg
Battery	1,5 kg	1,5 kg	1,5 kg
Turning radius (diameter)	1520 mm	1620 mm	1620 mm
Description	Specification for all configurations		
Strength tests according to	ISO 7176-8		
Ignitability of upholstery according to	ISO 7176-16		
EMC compliance	ISO 7176-21 / EN 61000-3-2 and EN 61000-3-3		
Power adapter / Transformer	Input: 100-240 V AC, 50/60Hz Max. output: 29V DC, 2.5A Protection class: IP66 Duty cycle: 2 min ON / 18 min OFF		
Battery	Capacity: 1,2 Ah Input: 29~45V DC Output: 24V DC, 1.2A Protection class: IP66 Duty cycle: 10% (2 min. ON / 18 min. OFF)		
Motor (2x)	Capacity: 1500N Motor speed: 2200RPM Umax 24VDC; I _{max} . 2,2 A Protection class: IP66, Duty cycle: 10% (Max.2 min. ON / 18 min. OFF)		
Handset	Protection class: IP66		
Use and storage temperature (battery)	+ 5 °C ~ + 45°C		
Storage and use humidity	30% ~ 70%		
We reserve the right to introduce technical changes. Measurement tolerance ± 15 mm / 1,5 kg / 1,5°.			
(*) Do not adjust the footrest in maximum length to prevent the footplate from touching the ground.			
(**) Tested in standard configuration			
NA Not applicable			



Service registration form

This product (name):

was inspected (I), serviced (S), repaired (R) or disinfected (D):

By (stamp): Kind of work: I / S / R / D Date:	By (stamp): Kind of work: I / S / R / D Date:	By (stamp): Kind of work: I / S / R / D Date:
By (stamp): Kind of work: I / S / R / D Date:	By (stamp): Kind of work: I / S / R / D Date:	By (stamp): Kind of work: I / S / R / D Date:
By (stamp): Kind of work: I / S / R / D Date:	By (stamp): Kind of work: I / S / R / D Date:	By (stamp): Kind of work: I / S / R / D Date:
By (stamp): Kind of work: I / S / R / D Date:	By (stamp): Kind of work: I / S / R / D Date:	By (stamp): Kind of work: I / S / R / D Date:
By (stamp): Kind of work: I / S / R / D Date:	By (stamp): Kind of work: I / S / R / D Date:	By (stamp): Kind of work: I / S / R / D Date:



Vermeiren GROUP
Vermeirenplein 1 / 15
2920 Kalmthout
BE

website: www.vermeiren.com

Instructions for specialist dealer

This instruction manual is part and parcel of the product and must accompany every product sold.

Version: C, 2020-11

Basic UDI: 5415174 122103Inovys II- U2

All rights reserved, including translation.

No part of this manual may be reproduced in any form what so ever (print, photocopy, microfilm or any other process) without written permission of the publisher, or processed, duplicated or distributed by using electronic systems.

© Vermeiren Group 2020